



Karnaugh Maps Adaptability to Implement Multiple-Actuator Pneumatic Circuits

ALZahraa Nather*
Amir Azizi***

Maher Yahya Salloom**
Sahala Siallagan****

**, ** Department of Mechatronics Engineering / Al-Khwarizmi College of Engineering/ University of Baghdad/ Iraq*

**** Department of Faculty Engineering/ Islamic Azad University/ Industrial Engineering /Tehran/ Iran*

***** Department of Mechanical Engineering Education/ Faculty of Engineering/ Universitas Negeri Madan/ Indonesia*

Corresponding Author: *Email: zahraa.nather1994@gmail.com

**Email: drmahir@kecbu.uobaghdad.edu.iq

***Email: azizi@srbiau.ac.ir

****Email: sahalaall@unimed.ac.id

(Received 4 May 2023; Accepted 19 October 2023; Published 1 March 2024)

<https://doi.org/10.22153/kej.2024.10.003>

Abstract

The pneumatic circuits have the benefit of having a low energy consumption and not polluting the air. Therefore, pneumatic installations are utilized in a variety of technological disciplines. The demands of industrial dynamics call for quick responses and minimal setup periods. Pneumatic equipment has to be adaptable and undergo ongoing production cycle changes to meet customer demands for flexibility. quick responses and minimal setup periods. Pneumatic equipment must be adaptable and undergo ongoing production cycle changes to meet customer demands for flexibility. This approach is often accomplished by completely rebuilding the system. The control system is part of it. It is easier to adjust to the new job cycle when the control system is included. By using the Karnaugh mapping technique, these problems can be solved. The technique enables circuit control with a (PLC). This study's goal is to minimize startup times by identifying the collection of ideal logical equations. Any pneumatic circuit may be electrically or pneumatically controlled according to the equation. This approach ease creates the process of creating sequence control scheme, whether the scheme uses electro-pneumatic systems or pure pneumatic control. This approach may guarantee both the intended sequential cycle and the least amount of command variables needed to run the control circuit.

This research demonstrates how to build a pneumatic control system for the coiling machine's six cylinders using Karnaugh Maps. The logical equations are generated in a simplified form using the stated principles, and they are easy to use both pneumatically and electro-pneumatically. To implement the technique, pneumatic/electro-pneumatic circuit simulation software is used (Automation Studio and Fluid Sim). Also, the technique includes Ladder Diagram Language transformation.

Keywords: Industrial automation, Karnaugh maps, Multiple pneumatic actuators, Pneumatic sequential circuits, programmable logic controllers (PLCs).

1. Introduction

Compressed air is among the oldest sources of energy. Compressed air is now widely distributed and used, and it may be found in all production and service industries. Pneumatic refers to the controlled use of this energy source and comes

from the Greek words meaning blow or breath. Drilling, tapping, and other similar operations are excellently suited for mechanization and process automation. Hence, the operations replace the human workforce [1]. Pneumatic movement of the actuators may be achieved in both translational and rotational directions by alternately adding air to the

This is an open access article under the [CC BY](https://creativecommons.org/licenses/by/4.0/) license:



actuator chambers. Directed control valves alternatively direct the compressed air flows to the actuator chambers in order to control this redirection. The execution of movement sequences is the goal of controlling these directional movements. The movement sequences (combinational / sequential cycles) do not present any difference. be combinational or sequential cycles, the control was performed using Karnaugh maps (KM's) methodology. In this work, the execution of the control of complicated sequential cycles, was taken into consideration. The execution is based on a set of KM derived optimum logic equations that allows for the control of an electrical or pneumatic system. With the help of this technique, pneumatic circuits may be controlled digitally (ON/OFF). By following the rules associated with the methodology, the recommended approach ensures that the needed sequential pneumatic cycle are be performed. In addition, the electrical control in the PLC is done. Moreover, the direct implementation of instructions obtained through the usage of the Karnaugh technique is conducted

The control equations become increasingly difficult to derive as the circuit complexity rises. That results from using more cylinders than before (auxiliary memory is frequently needed). Additionally, shorter production hours are required by the worldwide market for the industrial sector. It is possible to tackle these problems by applying the Karnaugh mapping technique. By identifying the set of reduced equations that enables every pneumatic circuit to be controlled electrically or pneumatically, the goal of this study is to construct multiple-actuator pneumatic circuits and reduce start-up times.

The authors in earlier studies [2-4] provided the following objectives: (1) establishing KM concepts using a single sequence, (2) using control mathematical equations for pneumatic circuits, (3) adaptation to relay electro-pneumatic control and with PLCs. References [2] and [4] explained how KM's equations were converted to the ladder schematic (LD) language for use with a Siemens S7 200 PLC in electro-pneumatic control applications. Using artificial intelligence (AI), the control equations were extracted [5]. When there are two alternative control sequences, a way for developing pneumatic control systems was created [6]. The technique for locating the command formulae for the triple sequence for a 4-cylinder, using the Karnaugh Maps, was described [7]. The author presented three different control sequences for five cylinders using the Karnaugh mapping

approach in [8]. In this work, the authors develop pneumatic control system in complex cases for 6 cylinders using Karnaugh Maps.

2. Methods and Characterizations

2.1 Pneumatic System

A Pneumatic control system is a collection of crucial components for industrial automation systems. Pneumatic control system includes many advantages:(1) low cost, (2) easy maintenance, (3) cleanliness, (4) ready availability, (5) inexpensive power supply [9]. By a cylinder and a group of directional control valves, pneumatic control is accomplished. The architecture of any pneumatic actuation system defined by these components is present in practically all pneumatic devices. Components may include control, actuation, and position aspects. Other components that may be employed in the circuits include logic components (AND, OR). The goal components is to guarantee that the precise timing of the signals and the compressed air supply to the cylinders is conducted in accordance with the required logic [6] [10]. Actuators are traditionally identified by capital letters, while actuator positions at limit switches are identified by lowercase letters. In this case, the cylinder are be represented by (A+) for forward movement and (A-) for a cylinder known as (A) to go rearward. The control cylinder's forward order corresponds to state (A+), while control cylinder's reverse order corresponds to state (A-). The directional control valve have a similar designation (A) as the control cylinder.

2.2 Karnaugh maps method

A Karnaugh map (KM) is a graphical method that minimizes Boolean expressions without the use of equation manipulation or Boolean algebra theories. A truth table can also be translated into the appropriate logic circuit using KM. That enables finding to quickly and methodically the smallest expression of the represented logic function [11]. In a broader sense, this approach addresses issues with industrial control. This technique can be used to create ON/OFF control systems with either compressed air or electricity as the command source. KM is widely used due to its simplicity. However, the k-map becomes challenging when the number of variables reaches 5, and 6, and nearly impossible when dealing with more than 6 [12].

KM is a table of cells. The table has $2n$ cells (where n is the number of variables).

The six-variable KM consist of 64 cells, this means the sixth variable has 4 KMs of 16 cells each. Variable B on the left chooses two of the four

KM in a row. For the top two KMs, the (b_0) , and for the bottom two KMs, the (b_1) , Figure (1). These KMs are topped by Variable A, which chooses two KMs column-wise. The (a_0) and (a_1) for the left and right KMs, respectively.

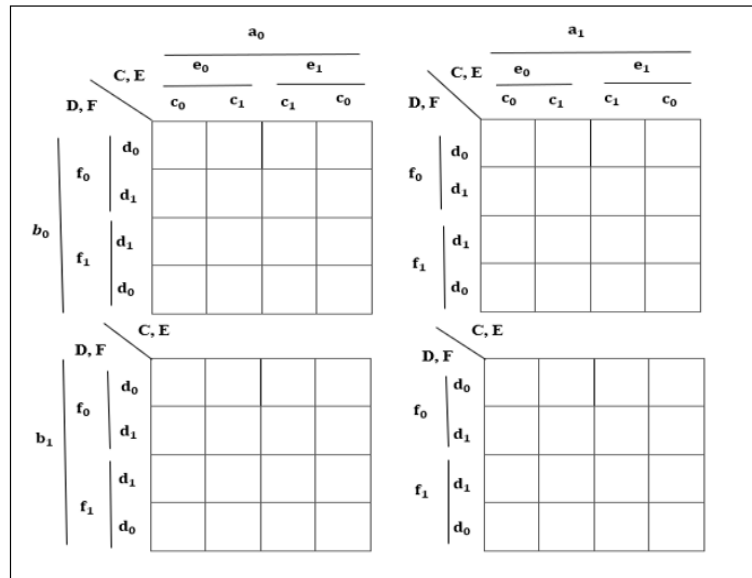

Fig. 1. Karnaugh maps for six variables (without memory).

The basic steps of the Karnaugh mapping for constructing electrical and pneumatic control

circuits. Figure 2 displays the block diagram of the working process.

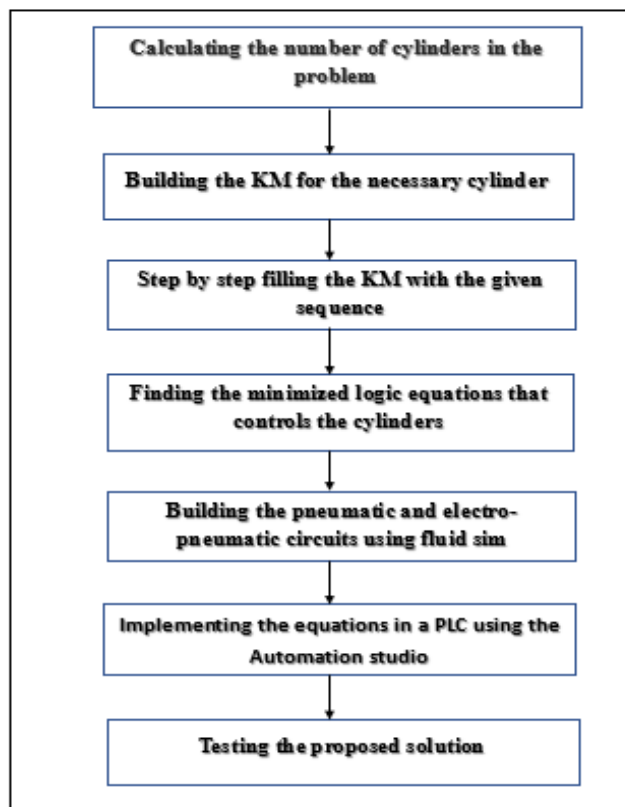

Fig. 2. Block diagram of Working Procedure.

2.3 Case study: Coiling machine using Karnaugh Maps

This case study involves a six-cylinder configuration Figure 3. The coiling machine plays an important role in various productions, this system is used in Baghdad/al-Rasheed/Al-Rowad Cables Company (privet Company) First, the cable is pushed to the rotating area under Cylinder B directly by the piston of the double-acting cylinder A. Next, the cylinder B piston rod is extracted to press the end of the cable to fix it, cylinder A returns, and the motor starts rotating to wind the cable in the form of a pulley. After winding is

completed and when the required size is reached, the cylinder C advances to cut the cable and then returns. The conveyor is then moved to the right by extracting the piston rod from cylinder D. After that, Cylinder E is extracted to tying the cable roll using plastic tape. Cylinder G moves to push the pulley from the conveyor to the box and return to its previous position and cylinder D is then retracted. This completes one working cycle. The cylinders must move in the order shown below for the process just described to be executed automatically:

A+ \ B+ \ A- \ C+ \ C- \ B- \ D+ \ E+ \ E- \ G+ \ G- \ D-



Fig. 3. Coiling machine.

The representation of the movements of a sequence can be done using the displacement diagram. Programming is made simpler and error-free by the displacement diagrams. In this case, to make the movements more understandable, they are shown in a displacement diagram. The movement chart is displayed in Figure 4. Description of the system components as shown in the following:

a0, a1: limit switch sensors for cylinder A
 b0, b1: limit switch sensors for cylinder B
 c0, c1: limit switch sensors for cylinder C
 d0, d1: limit switch sensors for cylinder D
 g0, g1: limit switch sensors for cylinder G
 e0, e1: limit switch sensors for cylinder E

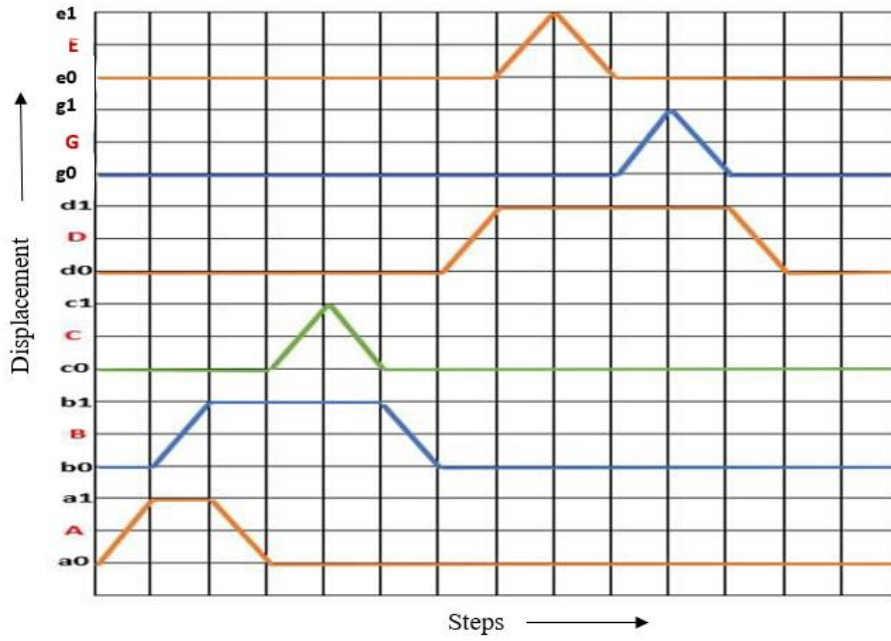

Fig. 4. Displacement diagram 2.3.1 Constructing the Karnaugh Maps.

A Karnaugh map for 6 variables (6 cylinders) $2^6=64$ cells are constructing using four 4-variable maps (16 cells each), Figure 5. Since more than

cylinder advance and back through the sequence, it requires the use of two memories (X) and (Y).

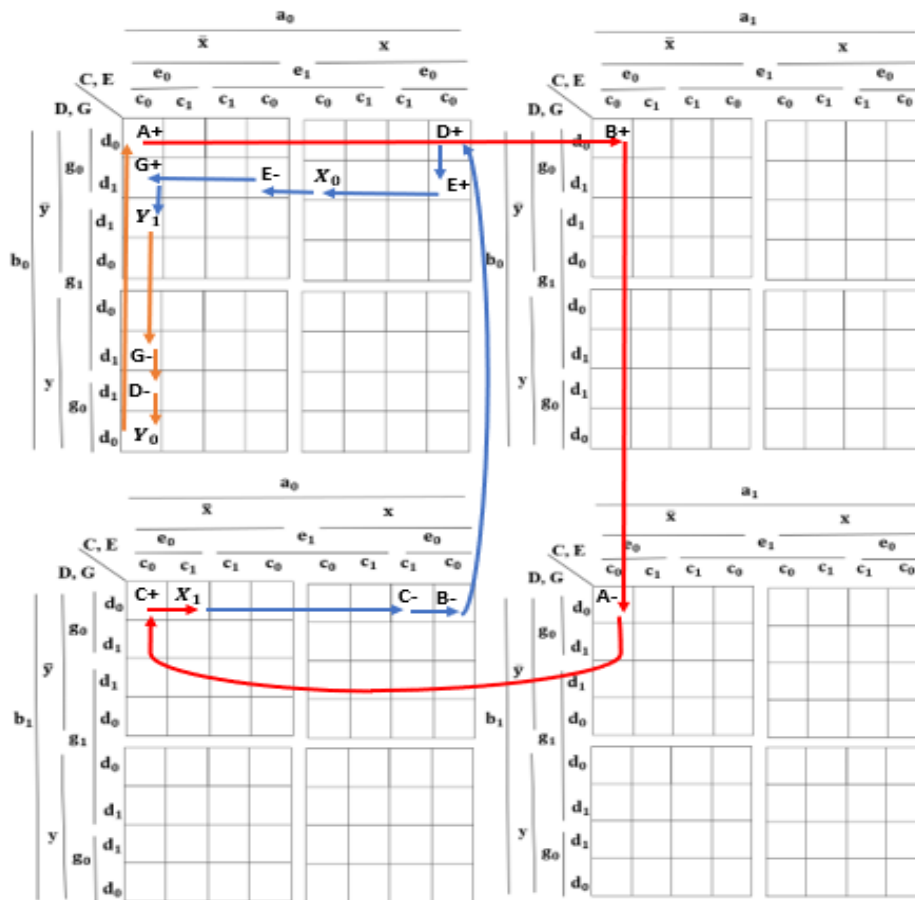

Fig. 5. Karnaugh Maps for Coiling machine with two memories (x and y).

2.3.2 Filling the Karnaugh Map

The sequence's first movement starts at the upper-left area of the map and only occupies one cell in the map. Every time there is a movement (A+, A-, B+, B-, etc.), the map must be stretched to twice as many columns. happens in an area that is already occupied. It is assumed that each valve is in its initial positions at the start of the sequence. A 5/2-way valve controls each cylinder. The feedback impulses come from sensors that are close by. All position sequence valve combinations are copied into the Km map step by step. as demonstrated by Table 1.

Table 1,
Relationship between variables and orders

End-of-stroke sensors (Initial position)	Valve control
$a_0 b_0 c_0 d_0 g_0 e_0$	A+
$a_1 b_0 c_0 d_0 g_0 e_0$	B+
$a_1 b_1 c_0 d_0 g_0 e_0$	A-
$a_0 b_1 c_0 d_0 g_0 e_0$	C+
$a_0 b_1 c_1 d_0 g_0 e_0$	C-
$a_0 b_1 c_0 d_0 g_0 e_0$	B-
$a_0 b_0 c_0 d_0 g_0 e_0$	D+
$a_0 b_0 c_0 d_1 g_0 e_0$	E+
$a_0 b_0 c_0 d_1 g_0 e_1$	E-
$a_0 b_0 c_0 d_1 g_0 e_0$	G+
$a_0 b_0 c_0 d_1 g_1 e_0$	G-
$a_0 b_0 c_0 d_1 g_0 e_0$	D-

3. Result and Discussion

This section presents the results of the Karnaugh map and Implementing Control. These controls were implemented using a PLC electro-pneumatic implementation, pure pneumatic control, and electrical contacts. That is to convert the equations generated from the KMs into control signals. Simpler logic equations were extracted by following the suggested rules, and it was based on the previous movement and its location in relation to memory. All active components must thus be present in the equation of motion associated with the A1 order. The active factors in this situation are \bar{y} (previous movement) and pressing start causes solenoid A+ to extend cylinder A. The final set of

equations are shown for all the cylinders using the same approach.

$$A_1 = start \bar{y} \quad \dots (1)$$

$$A_0 = b_1 \bar{x} \bar{y} \quad \dots (2)$$

$$B_1 = a_1 \bar{x} \bar{y} \quad \dots (3)$$

$$B_0 = c_0 x \bar{y} \quad \dots (4)$$

$$C_1 = a_0 b_1 \bar{x} \bar{y} \quad \dots (5)$$

$$C_0 = x \bar{y} \quad \dots (6)$$

$$D_1 = b_0 x \bar{y} \quad \dots (7)$$

$$D_0 = g_0 \bar{x} y \quad \dots (8)$$

$$E_1 = d_1 x \bar{y} \quad \dots (9)$$

$$E_0 = \bar{x} \bar{y} \quad \dots (10)$$

$$G_1 = e_0 d_1 \bar{x} \bar{y} \quad \dots (11)$$

$$G_0 = \bar{x} y \quad \dots (12)$$

$$X_1 = c_1 \quad \dots (13)$$

$$X_0 = e_1 \quad \dots (14)$$

$$Y_1 = g_1 \quad \dots (15)$$

$$Y_0 = d_0 \quad \dots (16)$$

3.1 Implementing Control from Karnaugh Maps

3.1.1 Pneumatic control and Electro pneumatic control

Electro-pneumatic and pneumatic circuits are handled using a software called Fluid SIM. Schematics for electrical systems can be used in actual systems once they are verified in simulations.

The pneumatic and electro-pneumatic circuit is built in accordance with the reduced logic equations, Figures 6 and 7. However, the memory is operated by pneumatic valve 5/2. The memory maintains a signal matching the sequence. Two memories, X and Y, are used in this simulation. The design of pure pneumatic circuit for the coiling machine includes pneumatic parts are: (1) six double acting cylinders cylinder A, B, C, D, G and E, (2)5/2-way directional valve solenoid operated for each cylinder to Control the piston movement, (3) exhaust to eliminate the pressure, (4)limit switch sensors two for each cylinder to sense the retracting and extending positions of the cylinders, (5)Compressor to compress the air to the desired working pressure. The pneumatic circuit is shown in Figure 6.

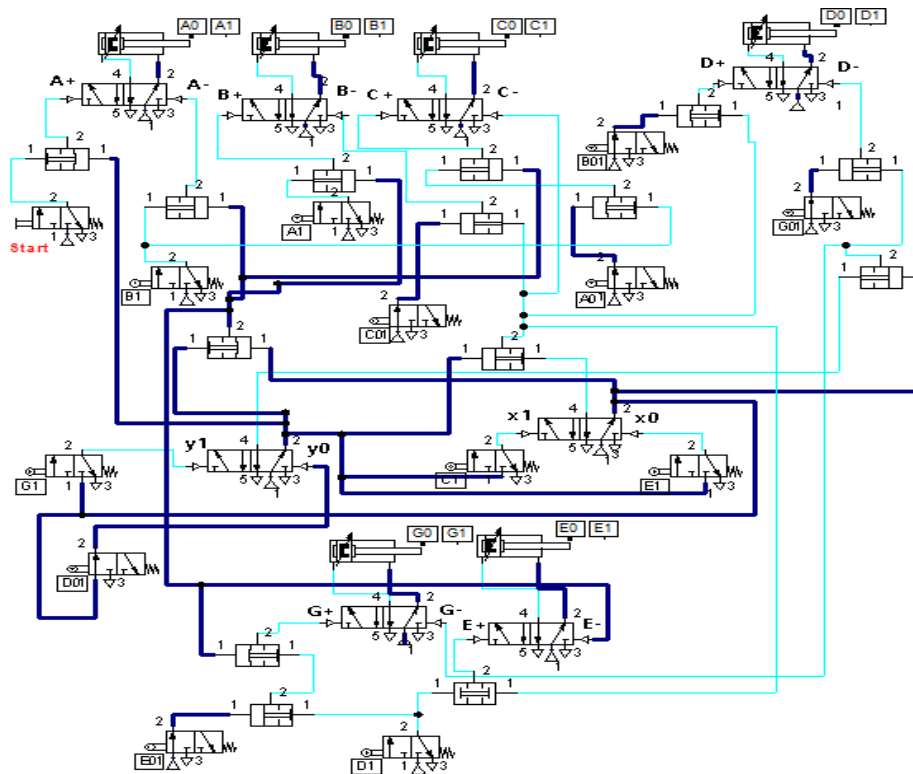
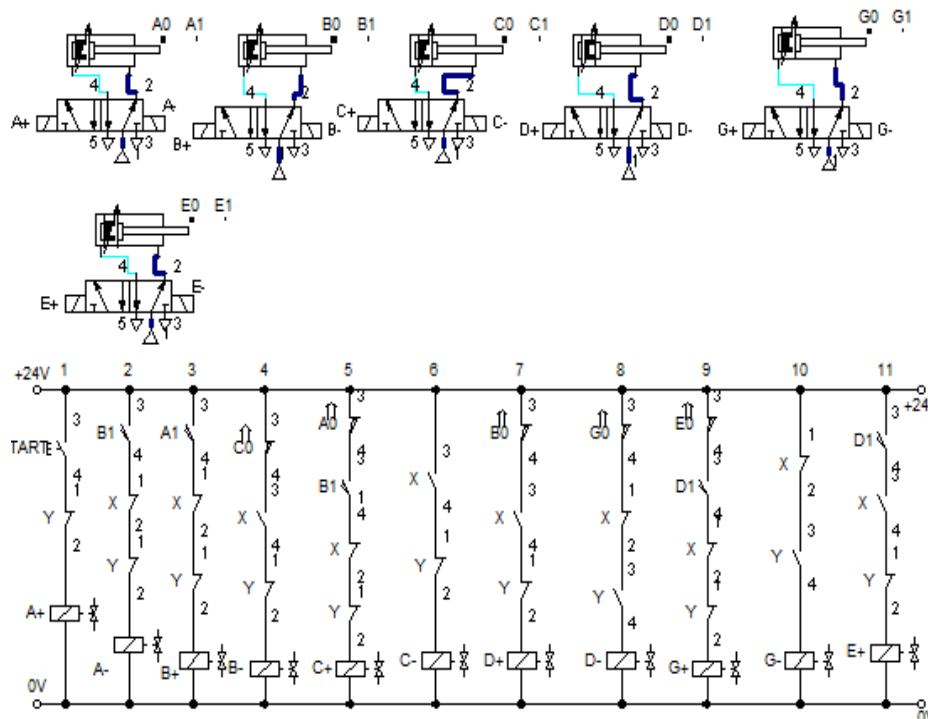

Fig. 6. Pneumatic circuit of coiling machine.

The electric parts are Push button to control the start of the system, normally open contacts, normally close contacts, and Coils, Figure 7. The optimized equations derived from the KMs are defined as an assemblage of input and output signals linked to multiple cylinder movements

during different cycles. The logical equations derived from the KMs are transposed to a contact diagram to create the complex sequence's electric scheme, which is made of a number of serial, parallel, or memory components.



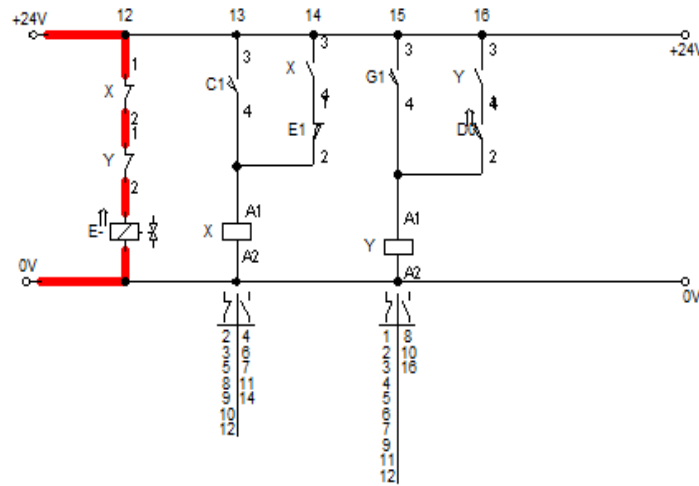

Fig. 7. Electro-pneumatic control.

3.1.2 PLC control

The KM equations may be used to easily build the electrical control of a pneumatic system; thus, the only necessary step is to turn the equations into PLC ladder logic. Implementing the required

memory that results from the replication of the map will be straightforward thanks to the flexibility of PLCs and the Ladder. With Ladder Logic, the simulation application Automation Studio (v7.0) is utilized to construct the program Figure (8).

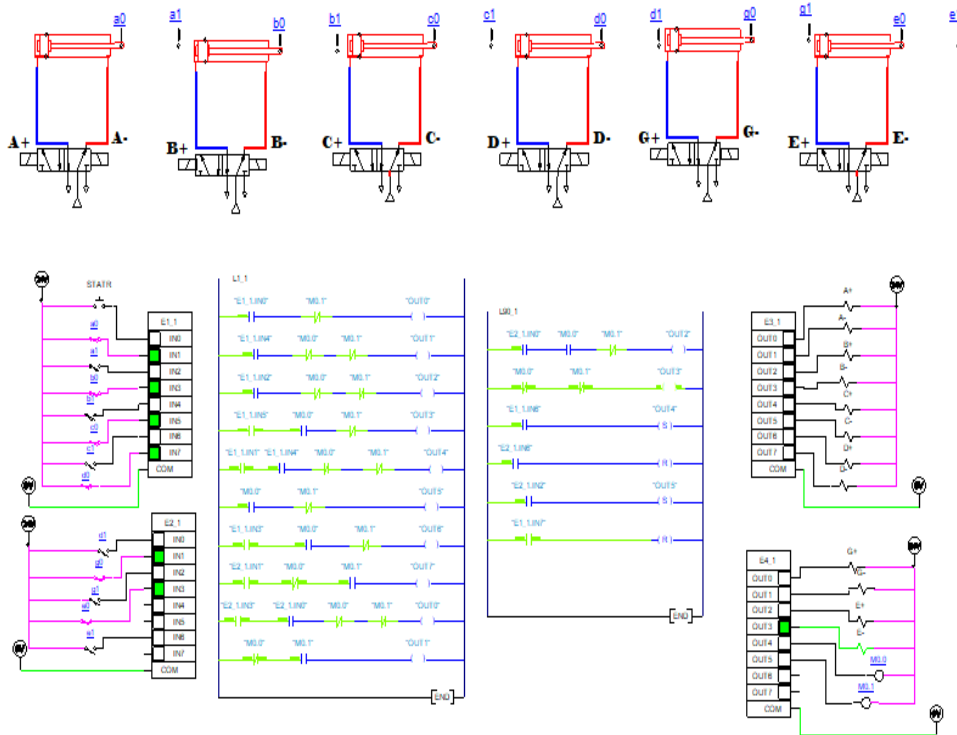

Fig. 8. Ladder implementation.

Utilizing a 1214C DC/DC/Rly CPU and TIA Portal V17 software, testing for the implementation and validation of the control system is done. In the first stage, tags are added to all digital inputs, outputs, and memory. Implemented THE PLC

PROGRAM as explained in Figure 9. Then, a ladder schematic (main OB) is constructed to do the project's necessary tasks and experimental work as shown in Figure10.

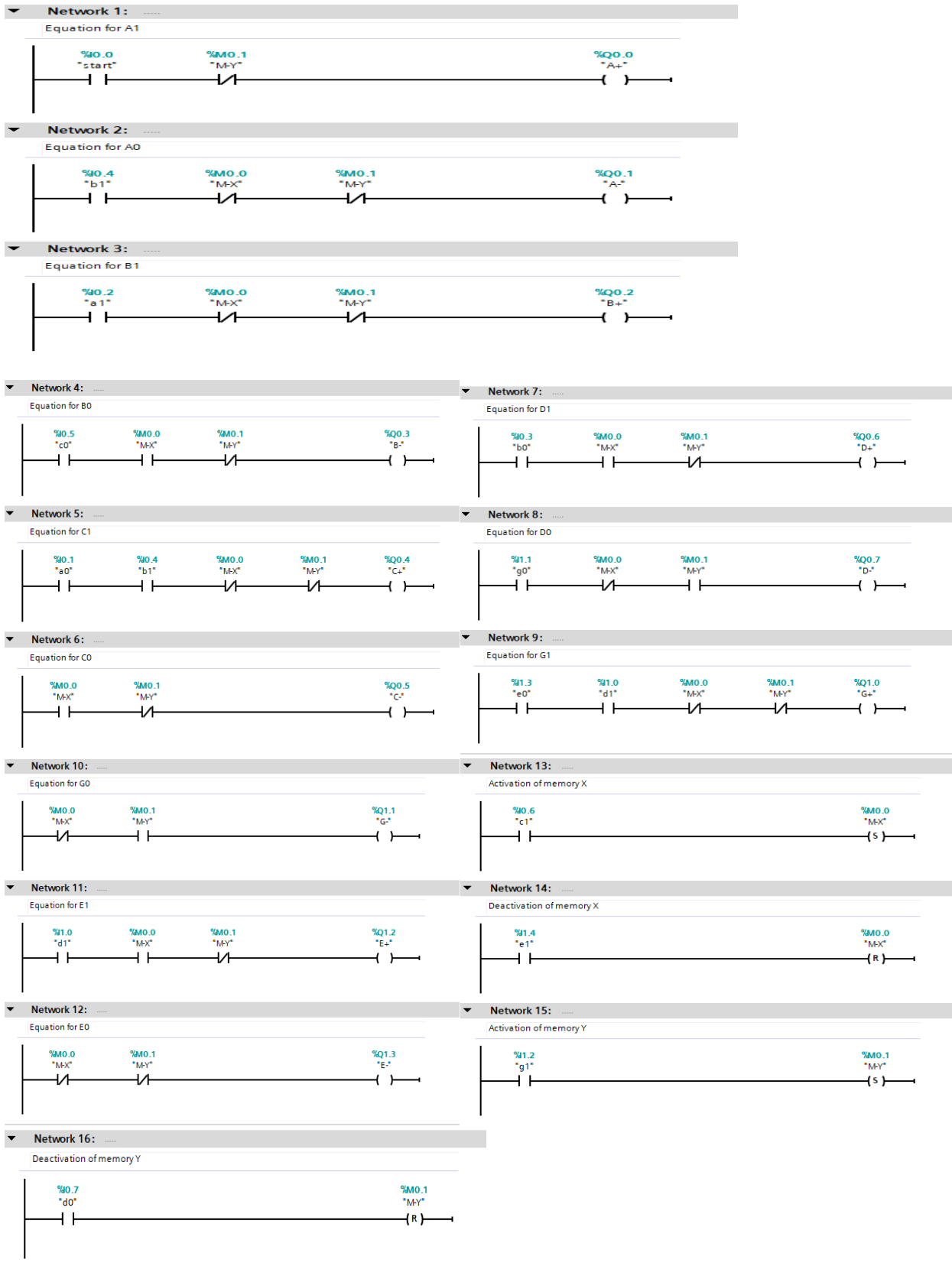

Fig. 9. PLC program in Ladder language.

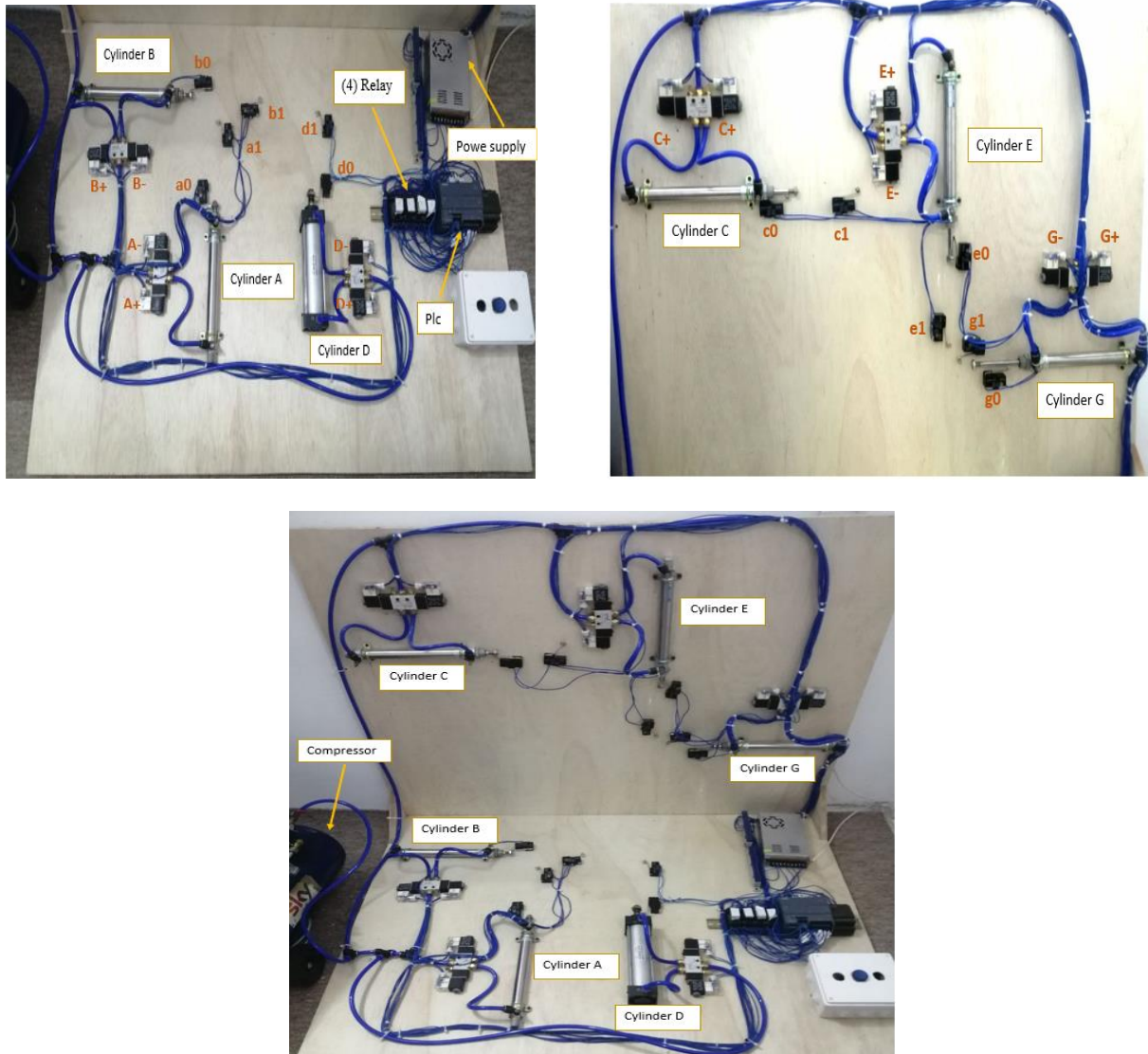

Fig. 10. a), b) and c) Experimental work.

4. Conclusions

A technique is presented that allows fast work in production cycles. They were modified for use with industrial electro-pneumatic and pneumatic control (PLC basis or relay). This method enables the resolution of an extremely complex control issue. The logic equations are extracted in a more straightforward form and are easy to employ both pneumatically and electro pneumatically by following the suggested rules. The command equations produced by KM ensure that the specified sequence will be carried out and that the number of command variables will be kept to a minimum. The equations may also be readily converted to the ladder diagram's language. This study may contribute to expanding the utility of pneumatic control methodologies. That is by

expanding their use beyond industrial applications. Applications may cover maintenance, process engineering, and education at the educational level of engineering, with a focus on automation of labs for electro-pneumatic sequential control and pneumatic control circuits.

References

- [1] A. Dakre, J. G. Sayed, E. A. Thorat, A. Ahamad, and M. A. Chaudhary, "Implementation of Bottle Filling and Capping Using Plc With Scada," *Int. Res. J. Eng. Technol.*, pp. 551–558, 2015, [Online]. Available: www.irjet.net.

- [2] A. Hussainbaig, R. Morales-menendez, and F. Guedea, "Electro Pneumatic Control versus Grafset."
- [3] A. A. Santos, "Teaching control pneumatic and electro- pneumatic circuits - a new method," no. September, pp. 1–4, 2015.
- [4] A. A. Santos and A. F. Da Silva, "Methodology for manipulation of Karnaugh maps designing for pneumatic sequential logic circuits," *Int. J. Mechatronics Autom.*, vol. 6, no. 1, pp. 46–54, 2017, doi: 10.1504/IJMA.2017.093307.
- [5] A. F. Da Silva and A. A. Santos, "A simulation tool using ai technics and karnaugh maps for learning and control digital pneumatics," *Proc. 2019 5th Exp. Int. Conf. exp.at 2019*, pp. 434–438, 2019, doi: 10.1109/EXPAT.2019.8876488.
- [6] A. A. Santos, "Karnaugh Maps Approach to Understanding Control Implementation behind Digital Pneumatics," no. December 2019, 2020
- [7] B. A. A. Santos and A. Ferreira, "Adaptability of Karnaugh Maps to Implement and Solve Complex Control Problems of Pneumatic and Electro-Pneumatic Systems," vol. 21, no. 2, 2021.
- [8] A. N. Fawzi and M. Y. Salloom, "Developing Multiple-Actuator Pneumatic Circuits Using the Karnaugh Maps Designing PLC Controlled," *J. Eur. des Systèmes Autom.*, vol. 56, no. 2, pp. 245–252, 2023, doi: 10.18280/jesa.560209.
- [9] K. Ahn and S. Yokota, "Intelligent switching control of pneumatic actuator using on/off solenoid valves," *Mechatronics*, vol. 15, no. 6, pp. 683–702, Jul. 2005, doi: 10.1016/j.mechatronics.2005.01.001.
- [10] B. Bajči, J. Šulc, V. Reljić, D. Šešlija, S. Dudić, and I. Milenković, "Remote laboratory for learning basics of pneumatic control," *Lect. Notes Networks Syst.*, vol. 22, no. January, pp. 144–150, 2018, doi: 10.1007/978-3-319-64352-6_14.
- [11] "Raf. J. of Comp. & Math's. , Vol. 14, No.1, 2020," vol. 1, no. 1, pp. 97–115, 2020.
- [12] Y. S. Abdalla, "Introducing the Yasser-map as an improvement of the Karnaugh-map for solving logical problems," *Proc. 2015 IEEE Int. Conf. Electr. Comput. Commun. Technol. ICECCT 2015*, pp. 4–8, 2015, doi: 10.1109/ICECCT.2015.7226152

تكيف خرائط كارنوف لتنفيذ دوائر هوائية متعددة المحركات هوائية متعددة المحركات

الزهرء نذير فوزي*

ماهر يحيى سلوم**

أمير عزيزي***

سأهالا سيالاكان***

*قسم هندسة الميكاترونكس/ كلية الهندسة الخوارزمي/ جامعة بغداد
***قسم الهندسة الصناعية/ كلية الهندسة/ فرع العلوم والبحوث/ جامعة اازاد الاسلامية/ طهران
****قسم تعليم الهندسة الميكانيكية / كلية الهندسة/ جامعة نيجيري ميدان/ اندونيسيا*البريد الالكتروني: zahraa.nather1994@gmail.com**البريد الالكتروني: drmahir@kecbu.uobaghdad.edu.iq***البريد الالكتروني: azizi@srbiau.ac.ir****البريد الالكتروني: sahalaall@unimed.ac.id

الخلاصة

تتمتع الدوائر الهوائية بميزة انخفاض استهلاك الطاقة وعدم تلويث الهواء. لذلك يتم استخدام التركيبات الهوائية في مجموعة متنوعة من التخصصات التكنولوجية. تتطلب متطلبات الديناميكيات الصناعية استجابات سريعة وفترات إعداد دنيا. يجب أن تكون المعدات الهوائية قابلة للتكيف وتخضع لتغييرات مستمرة في دورة الإنتاج من أجل تلبية متطلبات العملاء من حيث المرونة. غالبًا ما يتم تحقيق هذا النهج من خلال إعادة بناء النظام بالكامل، بما في ذلك نظام التحكم، في محاولة للتكيف مع دورة العمل الجديدة. باستخدام تقنية رسم الخرائط Karnaug، يمكن حل هذه المشاكل. تتيح هذه التقنية التحكم في الدائرة باستخدام وحدة تحكم قابلة للبرمجة (PLC) الهدف من هذه الدراسة هو تقليل أوقات بدء التشغيل من خلال تحديد مجموعة المعادلات المنطقية المثلى التي تسمح بالتحكم في كل دائرة تعمل بالهواء المضغوط كهربائيًا أو هوائيًا. سيسهل هذا النهج إنشاء مخطط التحكم في التسلسل، سواء كان يستخدم أنظمة كهربائية تعمل بالهواء المضغوط أو تحكمًا هوائيًا خالصًا. يضمن هذا النهج كلاً من الدورة التسلسلية المقصودة وأقل قدر من متغيرات الأمر اللازمة لتشغيل دائرة التحكم.

توضح هذه الدراسة كيفية استخدام خرائط Karnaug لإنشاء نظام تحكم هوائي لست أسطوانات في آلة اللف. باستخدام المبادئ المحددة، تم الحصول على المعادلات المنطقية في شكل مبسط، وهي سهلة الاستخدام بالهواء المضغوط والكهرباء الهوائية. لتنفيذ هذه التقنية، تم استخدام برنامج محاكاة الدوائر الهوائية / الكهربائية الهوائية (Automation Studio و Fluid Sim) يمكن أيضًا تحويلها إلى لغة مخطط السلم بسهولة.