



Modeling and Simulation of Hydraulic Proportional Control Valves with Different Types of Controllers

Sarah M. Rashid*, Maher Yahya Salloom**, Nor Haniza Bakhtiar Jemily ***
and Ab- Samat H. ****

*,**Department of Mechatronics Engineering, Al-khwarizmi College of Engineering, University of Baghdad, Baghdad, Iraq

***Mechanical Section, University Kuala Lumpur Malaysian Spanish Institute, Kulim Hi-Tech Park, Kulim 09000, Malaysia

****School of Mechanical Engineering, Engineering Campus, University Sains Malaysia (USM), 14300 Nibong Tebal, Seberang Perai Selatan, Pulau Pinang, Malaysia

Corresponding Author *Email: saramr@mtu.edu.iq

**Email: dmahir@kecbu.uobaghdad.edu.iq

***Email: norhaniza@unikl.edu.my

****Email: hasnida@usm.my

(Received 30 October 2023; Accepted 31 March 2024; Published 1 June 2024)

<https://doi.org/10.22153/kej.2024.03.001>

Abstract

Numerous applications have been developed, primarily focusing on achieving platform equilibrium. The system may employ electric motors or hydraulic cylinders, conventional valves, or a control mechanism that utilizes pressure sensors. The majority of these sources exhibit inaccuracies, demonstrate a sluggish response time, and may require periodic reorganization. Before implementing actual systems, it is imperative to develop a virtual system through the utilization of simulation techniques. This research aims to develop and evaluate a platform comprising two hydraulic cylinders and two proportional valves. The design of a hypothetical hydraulic system involves an analysis of the system and the derivation of its transfer function. Subsequently, the performance of the system is assessed by identifying the optimal approach for acquiring the parameters k_p , k_i , and k_d , an examination is conducted to optimize the existing genetic algorithm (GA) PID controller and the particle swarm optimization (PSO) algorithm through the utilization of MATLAB simulation. The results indicate that the genetic algorithm (GA) PID controller outperforms the particle swarm optimization (PSO) PID controller in enhancing system performance. The chosen error standard for the self-balance platform control system is the Integral Time Absolute Error (ITAE) type. The system exhibits an improved rate of convergence.

Keywords: Hydraulic; proportional; Mathematical model; Simulation; PID; Controller; Genetic Algorithm (GA); Particle Swarm Optimization (PSO)

1. Introduction

In the context of scientific and technological advancements, modern systems necessitate the attainment of optimal levels of performance and dependability by employing platform-stabilizing approaches. The stability systems of platforms demonstrate variety depending on the strategy employed for platform design and the mechanisms

utilized for governing and maintaining the platform's consistent level position. Maintaining the level of devices and equipment in laboratories is crucial for performance and preventing corrosion and damage to parts.

Utilizing the software tool ArchiCAD [1] begin the process of constructing a triangular-shaped balancing platform. The examined system is outfitted with a pair of hydraulic cylinders,

This is an open access article under the [CC BY](https://creativecommons.org/licenses/by/4.0/) license:



facilitating the manipulation of two independent degrees of freedom. A mathematical model was created to provide an accurate description of the behavior shown by this system. The present model was produced by applying an optimization methodology that incorporates both a genetic algorithm and a particle swarm optimization algorithm utilized, specifically, certain multi-robot systems. A comparison analysis was undertaken to assess the efficacy of these two optimization methodologies [2]. The hexapod parallel manipulator's stability was ensured through a specialized control system, incorporating advanced techniques like a telescopic boom and a gyroscopic self-leveling head for analysis[3]. The study focuses on creating a pedestal assembly for a medium-power transportable radar system, utilizing electromechanical and sliding actuators to adjust the azimuth and elevation settings of a 7-ton antenna [4]. The design of an electro-hydraulic-driven parallel stabilization platform requires careful consideration of factors like fluid stiffness, damping properties, and the coupling effect between the fluid and structure, which increases the complexity of the modal and dynamic response characteristics[5]. The study presents a

multipurpose amphibious platform for geognostic tasks in nearshore environments, regulated by flow rate and pressure, and using the Inertial Measurement Unit for seafloor alignment.[6]The study proposes a 6-DOF orthogonal hexapod with force feedback control for preventing vibration and steering of space observation systems, using hydraulic actuator force control.[7]The T shipborne-stabilized platform is crucial for maintaining shipborne equipment stability using the model predictive control approach (MPMPC), which predicts ship motion [8]. also, The Stewart platform is a mechanical system that comprises a mobile platform and a stationary base linked by six extensible legs. It functions as a motion base and incorporates prismatic, universal, and spherical joints[9].

2. Design Structure of the Platform

The system is designed utilizing the ArchiCAD drafting software, incorporating the necessary dimensions for implementation. As depicted in Figure (1) and presented in Table (1).

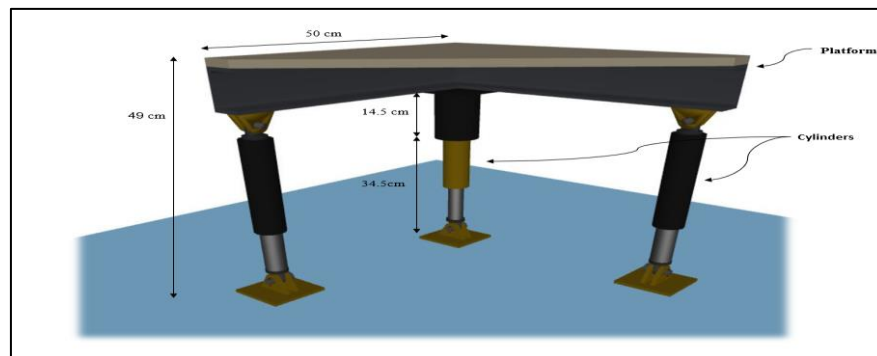

Fig .1. Structural design of stabilizer platform.

Table 1,
Mechanical properties of the platform.

Element	Value
The height of the platform	49 cm
Dimensions of the platform	50 cm
The initial stroke of reference	14.5 cm
The initial stroke of actuation cylinders	34.5cm

2. Methodology

2.1 Mathematical models

The system is comprised of a pair of hydraulic cylinders equipped with two proportional control valves. The purpose of this mechanism is to control

the horizontal and vertical displacements of every axis. The mathematical model of the system encompasses the proportional control valve and cylinder in isolation. In situations where load reactive forces cannot be disregarded, the input of the system is represented by the valve spool displacement, denoted as x , while the output of the

system is represented by the power piston displacement, denoted as y .

The linearization of a hydraulic system Figure (2): (a) depicts a hydraulic motor. The device can be described as a hydraulic power amplifier and actuator that is regulated by a pilot valve. The pilot valve exhibits a balanced configuration, wherein the pressure forces exerted against it are uniformly distributed. The pilot valve possesses the capability to effectively manage a very high-power output while requiring minimal force for positioning. The relationship exhibits nonlinearity and can be transformed into a linear form by using

ordinary differential equations (ODEs), with P_s representing the pressure pump.

Figure (2) : (b) depicts an expanded depiction of the valve orifice area. The valve orifice areas of ports 1, 2, 3, and 4 shall be referred to as respective designations. The variables $A_1, A_2, A_3,$ and A_4 are being referred to. Furthermore, let us denote the flow rates through ports 1, 2, 3, and 4 as $q_1, q_2, q_3,$ and $q_4,$ respectively. It should be noted that A_1 is equal to A_3 and A_2 is equal to A_4 due to the symmetrical nature of the valve. Given the assumption that the displacement x is small,[10]

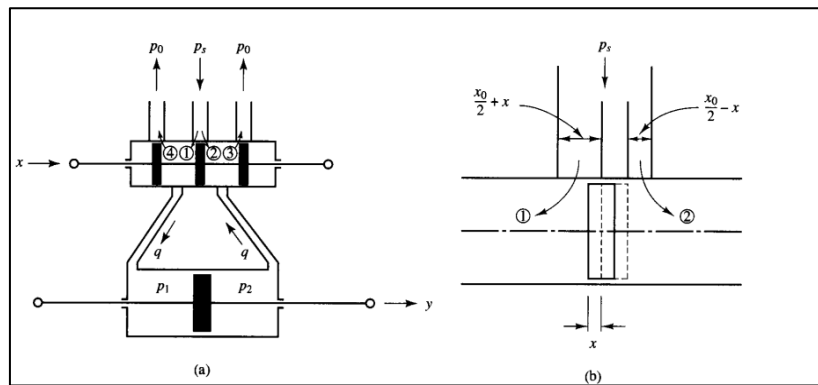

Fig. 2. (a) hydraulic system (b) enlarged diagram of valve orifice area[10].

$$A = \left(\frac{x}{2} + X\right) K \quad \dots (1)[10]$$

Where A is an area, k is a constant, x_0 is a displacement.

In addition, we presume that the return pressure p_0 in the return line is negligible and therefore can be disregarded. Then, using Figure (2) :(a) as a reference, the flow rates through valve orifices are measured as follows:

$$Q = CA \sqrt{\frac{2g \Delta P}{\gamma}} \quad \dots (2)[10]$$

Where (C) is discharge and (γ) is specific weight. (g) is the acceleration of gravity. The flow rate (g) to the left-hand side of the e power piston is:

$$Q = \left(\frac{x}{2} + X\right) K \sqrt{\frac{2g \Delta P}{\gamma}} \quad \dots (3)[10]$$

$$Q = C\sqrt{\Delta P} \left(\frac{x}{2} + X\right) \quad \dots (4)[10]$$

By applying the linearization technique

$$Q = k_1 x - k_2 \Delta p \quad \dots (5)[10]$$

Where Δp the pressure drops across the orifice is a function of the supply pressure P_s and the pressure difference $\Delta p = P_1 - P_2$.

$$\text{Also, } q = A \frac{dy}{dt} \quad \dots (6)[10]$$

Where $\frac{dy}{dt}$ the speed of the piston Mass

$$\sum F = m \ddot{y} \quad \dots (7)[10]$$

Tack Laplace transform:

$$Q(s) = k_1 X(s) - k_2 \Delta P(s) \quad \dots *5$$

$$q = A s Y(s) \quad \dots *6$$

$$A \Delta P(s) = Y(s) [m s^2 + c s + k] \quad \dots *7$$

rearrangement equation 3.

$$\Delta P(s) = \frac{Y(s)[m s^2 + c s + k]}{A} \quad \dots (8)$$

After substituting the equations, we get:

$$T(s) = \frac{Y(s)}{X(s)} = \frac{k_1}{\frac{k_2}{A}[m s^2 + (c-A)s + k]} \quad \dots (9)$$

Based on parameters taken from previous research (k_1, k_2, c, k).[11] .Additionally, it has the potential to be utilized within this particular system. The values of (A, m) are assumed to be from the real system. Table 2 provides a comprehensive overview of the information presented.

$$T(s) = \frac{0.0825}{1.716 s^2 + 56.378 s + 3575} \quad \dots (10)$$

$$T(s) = \frac{0.04807}{s^2 + 32.854 s + 2083.33} \quad \dots (11)$$

Table 2,
parameters of hydraulic system[12][13][11]

parameters	value	unit	description
k_1	0.0825	m/A	Gain of spool valve(vertical)
k_2	8.25e-5	m/mA	Gain of spool valve (lateral, Longi)
A	1.256e-3	m ²	Piston area of lateral axis
m	13	kg	Load mass
c	400	Ns/m	Load damping
k	2500	N/m	Load spring stiffness

2.2 PID controller

A proportional integral derivative (PID) controller is an automated and precise control system utilized for regulating various parameters, such as temperature, pressure, and speed, to achieve desired values. Control loop feedback is the fundamental mechanism employed in PID controllers. A PID algorithm computes the error by determining the discrepancy between the current value and the target value and subsequently adjusts the controlling parameters accordingly. This error is iteratively computed until the process terminates. The proportional component is utilized to quantify the discrepancy between the desired value and the actual value, and it is accountable for generating the remedial response. The integral is utilized to compute the cumulative sum of historical error values, which is then integrated to determine the integral term. When a mistake is removed from the system, the rate of increase of this integral ceases. The derivative is employed to forecast the anticipated error levels in the future, relying on the current values. The controlling effect can be enhanced by having a system with a high rate of change, which is likewise dependent on derivatives. The name "Proportional Integral Derivative (PID) Controller" is derived from the combination of these three operations [11].

$$\text{Output} = K_p e(t) + K_i \int e(t) dt + K_d \frac{d}{dt} e(t) \dots (12) [11]$$

Where:

e = setpoint -Input

K_p = proportional constant

K_i = integral constant

K_d = derivative constant

2.3 GA algorithm

Genetic algorithms (GAs) are grounded in fundamental principles such as natural selection and natural inheritance. Natural selection refers to the process through which organisms with advantageous adaptations to their environment are more likely to survive and reproduce, while those

lacking such adaptations are more likely to be removed. This elimination occurs due to the absence of favorable hereditary traits, which are passed on through the interbreeding of selected individuals to generate offspring. In the context of genetic algorithms (GA), the initial population is determined using a fully random process in Georgia. The subsequent stages of GA can be categorized into two distinct phases: genetic operations, which involve crossover and mutation, and evolutionary processes, which encompass selection. The initial step in problem-solving involves encoding a set of points, known as genetic algorithms (GAs). Every configuration generates a collection of potential solutions, referred to as a chromosome or individual, within the population. [14]Chromosomes consist of sequences of genetic material known as genes.

The design process is utilized to create an appropriate algorithm. The genetic algorithm (GA) is elected as the method of choice for optimizing the parameters of the PID controller, specifically k_p , k_i , and k_d , through a self-tuning process. The design process revolves around the utilization of a genetic algorithm (GA) to optimize the classic proportional-integral-derivative (PID) controller for self-balance platform control [15].

Empirical investigations have demonstrated that the use of the Genetic Algorithm (GA) and the Proportional-Integral-Derivative (PID) controller yields superior outcomes in the regulation of self-balancing robots compared to traditional PID control methods [14].

2.4 PSO algorithm

Particle swarm optimization (PSO) is a widely recognized and influential optimization method that draws inspiration from natural swarm behavior. The popularity of this nature-inspired technique has experienced a significant surge due to its inherent characteristics of flexibility and ease of implementation. Particle swarm optimization (PSO) has garnered significant attention across various domains of academic inquiry [13].

3. Simulation and Experiment

This section presents the simulation model of a self-balancing platform, the input and output systems and the transfer functions of the platform. Figure 3 presents the simulation model with a conventional PID controller, which enhances the performance of the self-balancing platform. The simulation model is shown in Figure 4. It uses a

genetic algorithm (GA) to find the most important changes needed by choosing the best values for the PID controller's parameters. This makes the system better. while Figure 5 illustrates the simulation model utilizing the Particle Swarm Optimization (PSO) algorithm to identify crucial adjustments by selecting optimal values for the control parameters of the proportional-integral-derivative (PID) controller for system optimization

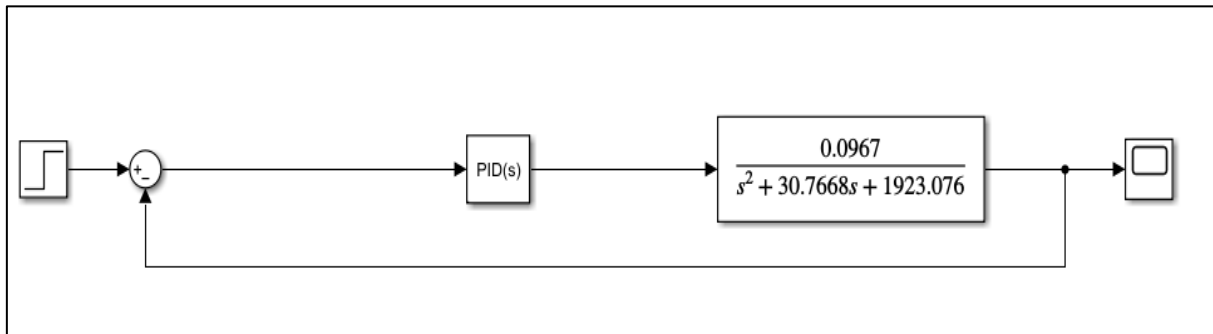

Fig. 3. Simulation model of self-balance platform with tuning PID controller.

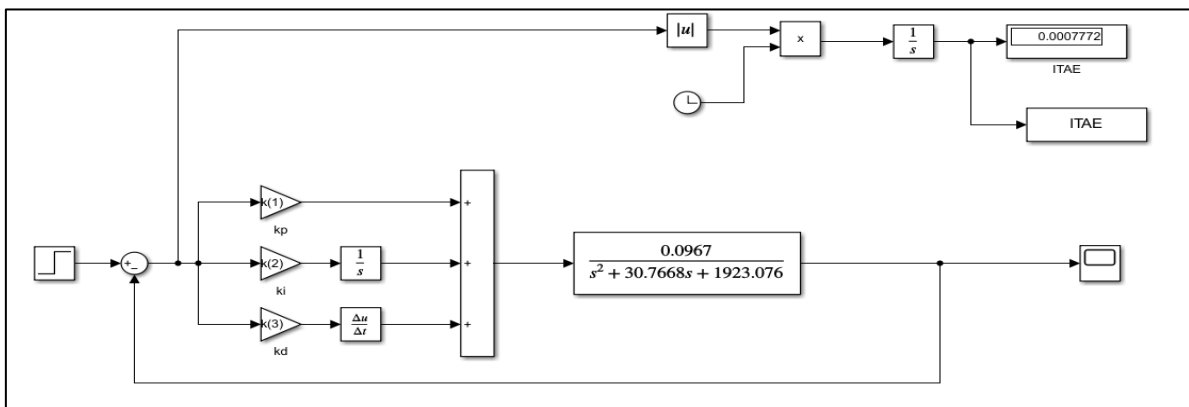

Fig. 4. Simulation model of self-balance platform with GA-PID controller.

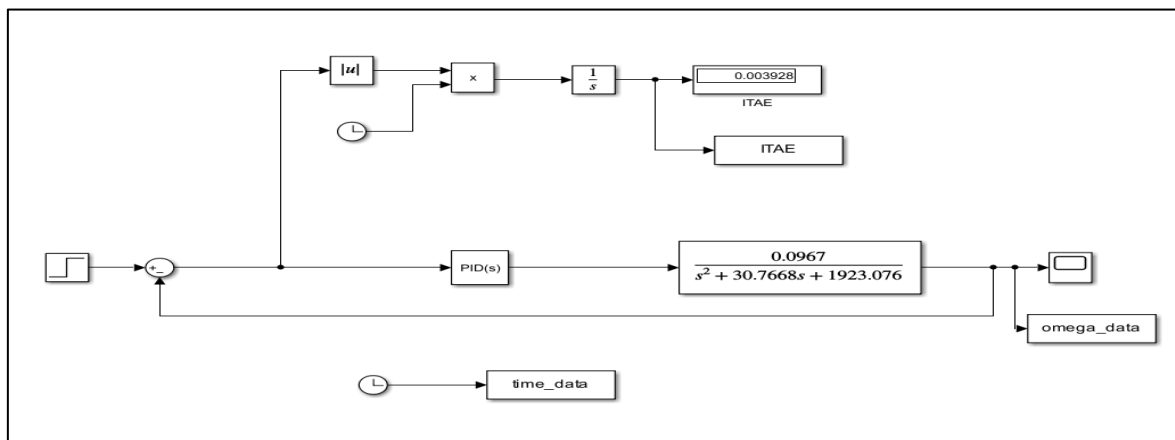

Fig. 5. Simulation model of a self-balance platform with PSO-PID controller.

4. Simulation Results

In this section, there are three parts. The first part is the simulation results with the PID Controller shown in subsection 4.1. The second

part is the simulation results with the GA_PID controller that is shown in subsection 4.2. The third part is the simulation results with the PSO-PID controller that is shown in subsection 4.3

Table 2,
System parameters in each optimization method.

parameters	Raise time(sec)	Settling time (sec)	Overshoot
PID	0.0247	0.189	0.181%
GA-PID	0.0294	0.136	8.7663
PSO-PID	0.0194	0.1926	0.0046

Table 3,
The detailed MATLAB results.

parameters	KP	KI	KD
PID	36683.9058	819836.3269	406.5704
GA-PID	0.3112×10^5	8.8982×10^5	0.0045×10^5
PSO-PID	0.349×10^5	8.8909×10^5	0.0044×10^5

4.1 Simulation results with PID controller

This section examines the system's response when a PID controller is employed to enhance the operation and performance of a self-balancing platform. The results presented in Figure 6 demonstrate the system's response, which exhibits a reduction in overshoot to 0.181%, a rise

time of 0.0247 seconds, and a settling time of 0.189 seconds. Consequently, the system achieves a steady state in a shorter duration compared to the initial scenario in the absence of the controller. The parameters of the PID controller are assigned as follow: $K_p = 36683.9058$, $K_d = 406.5704$, and $K_i = 819836.3269$.

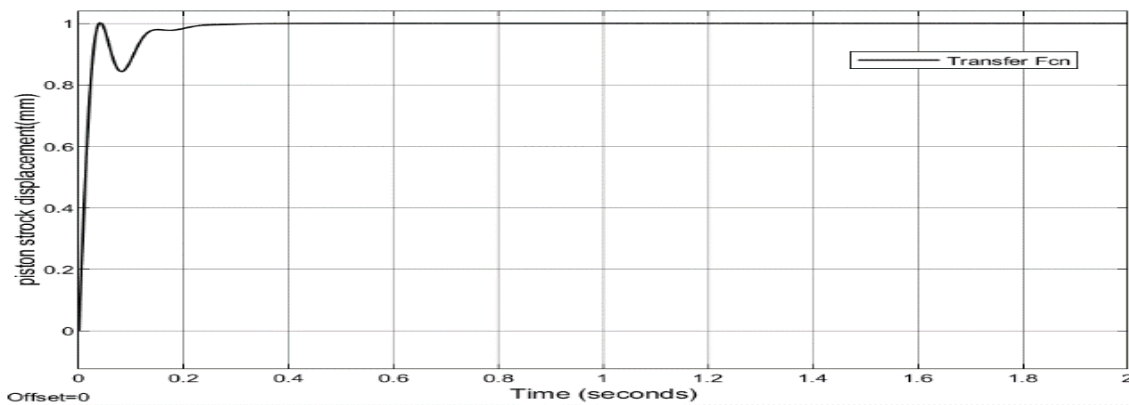

Fig. 6. piston stroke displacement using PID Controller.

4.2 Simulation results with PID controller

This section focuses on the application of genetic-PID optimization to enhance the response of the self-balancing platform and achieve optimal outcomes. The aim is to enhance the performance and functionality of the proportional control valve

by optimizing the parameters of the PID controller. Figure 7(a) depicts the system's response obtained by the utilization of GA-PID

optimization. The provided data demonstrates that the overshoot value is 8.7663, the settling durations for each instance are 0.0294 seconds, the rise time is 0.1316 seconds, and the system

achieves a steady state in a significantly shorter duration compared to previous states. At iteration 100, the control parameters have the following

values: $K_P = 0.3112 \times 10^5$, $K_d = 0.0045 \times 10^5$, and $K_i = 8.8982 \times 10^5$. In Figure 7 (b), the optimization tools utilized for GA-PID are depicted.

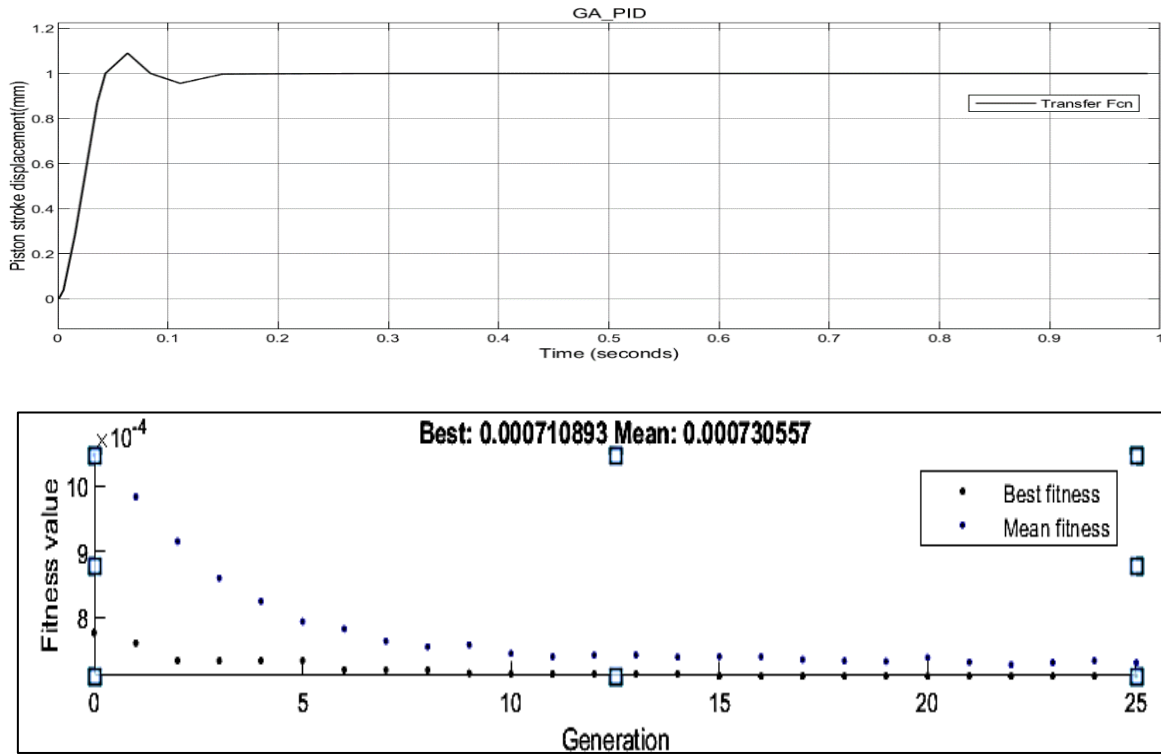

Fig. 7. (a) Piston stroke displacement using GA_PID controller (b) Piston stroke displacement using GA_PID Controller at iteration 100.

4.3 Simulation results with PSO-PID controller

This part is dedicated to examining the utilization of PSO-PID optimization in order to improve the response of the self-balancing platform and attain optimal results. The objective is to improve the operational efficiency and capabilities of the proportional control valve through the optimization of the PID controller's parameters. The response of the system acquired

by the application of PSO-PID optimization is illustrated in Figure 8. The data supplied indicates that the overshoot value is 0.0046. The settling durations for each instance are measured at 0.1926 seconds, while the rise time is also 0.1926 seconds. Furthermore, it is observed that the system achieves a steady state with a considerably shorter duration compared to previous states. At the 100th iteration, the control parameters are seen to possess the subsequent values: $K_P = 0.349 \times 10^5$, $K_d = 0.0044 \times 10^5$, and $K_i = 8.8909 \times 10^5$.

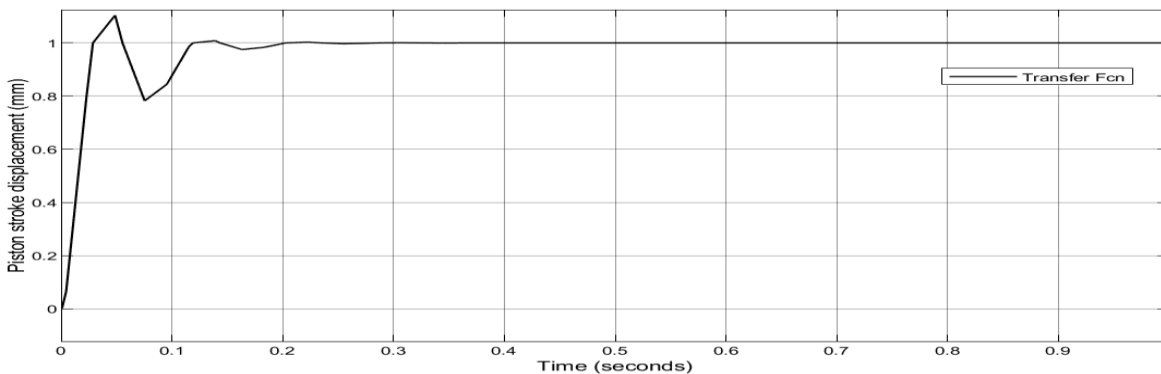

Fig. 8. Piston stroke displacement using PSO-PID controller.

5. Conclusion

The paper introduces the PSO approach as a means of modifying the control parameters of the conventional PID controller utilized in the construction of a self-balancing platform control system.

The study proposes the utilization of a genetic method to modify the control parameters of the conventional PID controller, which was originally built for a self-balancing platform control system. The genetic controller exhibits significantly faster temporal response qualities in comparison to the PID controller, and it further furnishes us with the starting point for the control parameter values. The GA-PID controller demonstrates superior performance in terms of settling time, rising time, and overshoot. Furthermore, it should be noted that the error margin associated with GA-PID is significantly lower compared to conventional control methods. As a result, GA-PID has proven to be highly effective in achieving optimal outcomes for the self-balance platform.

References

- [1] Graphisoft, "ArchiCAD 22." Budapest, Hungary. [Online]. Available: <http://www.graphisoft.com/archicad/>
- [2] W. H. Bangyal *et al.*, "An Improved Particle Swarm Optimization Algorithm for Data Classification," *Applied Sciences (Switzerland)*, vol. 13, no. 1, 2023, doi: 10.3390/app13010283.
- [3] W. P. Hunek *et al.*, "A Measurement-Aided Control System for Stabilization of the Real-Life Stewart Platform," *Sensors*, vol. 22, no. 19, pp. 1–12, 2022, doi: 10.3390/s22197271.
- [4] S. Kumar, S. Pazhanivel, K. A. Kumar, and N. M. Athawale, "Design and Development of Pedestal Assembly for Medium Power Active Array Transportable Radar," vol. 2015, no. December, pp. 2–5, 2015.
- [5] W. Wang, "Analysis of Vibration Characteristics of Electro-hydraulic 3-UPS / S Parallel Stabilized Platform," pp. 0–13, 2023.
- [6] L. Pugi *et al.*, "Development of a Multifunctional Amphibious Platform for near Shore Geognostic Activities," *Chem Eng Trans*, vol. 91, no. April, pp. 163–168, 2022, doi: 10.3303/CET2291028.
- [7] M. Taghizadeh and M. Javad Yarmohammadi, "Development of a Self-tuning PID Controller on Hydraulically Actuated Stewart Platform Stabilizer with Base Excitation," *Int J Control Autom Syst*, vol. 16, no. 6, pp. 2990–2999, 2018, doi: 10.1007/s12555-016-0559-8.
- [8] H. Qiang, S. Jin, X. Feng, D. Xue, and L. Zhang, "Model predictive control of a shipborne hydraulic parallel stabilized platform based on ship motion prediction," *IEEE Access*, vol. 8, pp. 181880–181892, 2020, doi: 10.1109/ACCESS.2020.2992458.
- [9] M. Becerra-Vargas and E. M. Belo, "Application of H1 theory to a 6 DOF flight simulator motion base," *Journal of the Brazilian Society of Mechanical Sciences and Engineering*, vol. 34, no. 2, pp. 193–204, 2012, doi: 10.1590/S1678-58782012000200011.
- [10] VARIOS, "Modern Control Engineering by K. OGATA (Solucionario).pdf."
- [11] J. W. Kim, D. J. Xuan, and Y. B. Kim, "Robust control application for a three-axis road simulator," *Journal of Mechanical Science and Technology*, vol. 25, no. 1, pp. 221–231, 2011, doi: 10.1007/s12206-010-1104-y.
- [12] P. I. I. Data, "Valves, Direct Operated, Without Electrical Position Feedback," pp. 1–12.
- [13] Jain, Meetu, et al. "An overview of variants and advancements of PSO algorithm." *Applied Sciences* 12.17 (2022): 8392.
- [14] P. Karpagavalli and A. Ebenezer Jeyakumar, "Simulation analysis on proportional integral and derivative control of closed loop DC motor drive with bipolar voltage switching," *Am J Appl Sci*, vol. 10, no. 7, pp. 714–723, 2013, doi: 10.3844/ajassp.2013.714.723.
- [15] H. S. Dakheel, Z. B. Abdullah, and S. W. Shneen, "Advanced optimal GA-PID controller for BLDC motor," *Bulletin of Electrical Engineering and Informatics*, vol. 12, no. 4, pp. 2077–2086, 2023, doi: 10.11591/eei.v12i4.4649.

نمذجة ومحاكاة صمامات التحكم التناسبي الهيدروليكي مع أنواع مختلفة من وحدات التحكم

ساره محمد رشيد*، ماهر يحيى سلوم**، نور هانيزا باكثر جميلي***،

عبد الصمد هاسنيدا****

**قسم هندسة الميكاترونكس، كلية الهندسة الخوارزمي، جامعة بغداد، بغداد، العراق

***القسم الميكانيكي، المعهد الإسباني الماليزي بجامعة كوالالمبور، مجمع كوليم للتكنولوجيا الفائقة، كوليم 09000، ماليزيا

****كلية الهندسة الميكانيكية، مجمع الهندسة، جامعة العلوم الماليزية (USM)، 14300 بيونك تيبال، سيبيرانك بيراي الجنوبية، جزيرة بينانك، ماليزيا

*البريد الإلكتروني: saramr@mtu.edu.iq

**البريد الإلكتروني: dmahir@kecbu.uobaghdad.edu.iq

***البريد الإلكتروني: norhaniza@unikl.edu.my

****البريد الإلكتروني: hasnida@usm.my

المستخلص

ترمي هذه الدراسة إلى تصميم منصة ذاتية التوازن وتطويرها وتستخدم في العديد من التطبيقات الصناعية التي تحتاج الى استواء سطح المنصة لضمان عملها بكفاية عالية. تم تصميم منصة وتنفيذها تتكون من اسطوانتين هيدروليكية يتم التحكم بهما عن طريق صمامي سيطرة هيدروليكية تناسبية. يتضمن تصميم النظام الهيدروليكي الافتراضي تحليل النظام واشتقاقه. وبعد ذلك، تم تقييم أداء النظام من خلال تحديد النهج الأمثل للحصول على البيانات kp و ki و kd . من خلال استخدام محاكاة MATLAB، تم إجراء فحص لتحسين وحدة التحكم PID للخوارزمية الجينية (GA) الحالية وخوارزمية تحسين سرب الجسيمات (PSO). تشير النتائج إلى أن خوارزمية التحكم PID للخوارزمية الجينية (GA) تتفوق في تحسين أداء النظام من خوارزمية تحسين سرب الجسيمات (PSO) وكان معيار التحكم في الأخطاء الذي تم اختياره لنظام التحكم في منصة التوازن الذاتي هو نوع الخطأ المطلق للوقت المتكامل. (ITAE). يُظهر النظام معدلًا محسنًا للتقارب.